

ITAS Dryflame



Plug and play packaged burner

- High on ratio turn down
- Compact design
- Increased efficiency
- Easy servicing
- Reliable performance
- Air and gas controlled
- Reduced commissioning time

Fives designs and manufactures your direct fired process

ITAS Dryflame burners are mainly used in direct- or indirect- fired Hot Gas Generator applications that require packaged and easy to fit pre-tested burner units to reduce installation time. ITAS Dryflame Pack burners packages include burner, combustion air fan, gas train and all the necessary components to ignite and safely control the burner operations. Flame testing procedures are carried out prior to shipment to guarantee a flawless burner performance. Controlling the air and gas flow to the burner increases overall combustion and system efficiency. Flame supervision is ensured by a UV scanner or flame rod.

ITAS DRYFLAME PACK CONFIGURATION

ITAS Dryflame burners are packaged into 8 complete sizes to meet any customer need and process necessity.



TYPICAL INDUSTRIES AND APPLICATIONS

- Food & feed: Drying of ingredients, baking
- Aluminium: Aging, homogenizing
- Glass (cold end): Lehrs, tempering and annealing lines
- Automotive: Paint drying, curing
- Ceramics: Drying
- Textile: Drying, coating
- Printing Industry: Drying after printing

HIGH TURN DOWN

ITAS Dryflame burners are designed with an advanced air/fuel ratio system to provide a very high on ratio turn down. These parameters are a requirement for ovens and dryers with regular standby operation mode due to product changes and process settings.

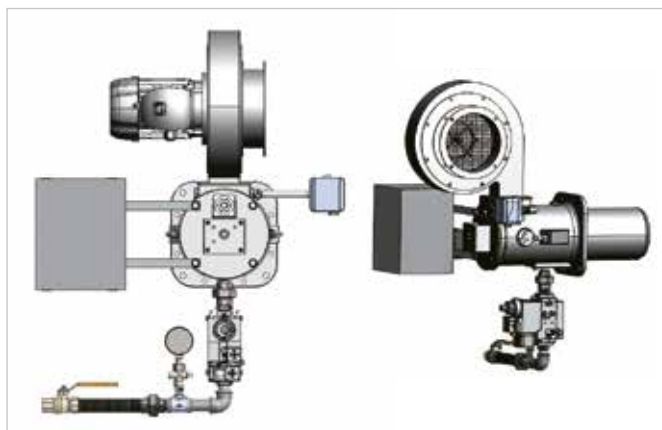

TECHNICAL PARAMETERS

- Capacity: 125 to 1500 kW(lhv)
- Turn down: up to 20: 1
- Fuel: Natural gas, propane, others on request
- Process air: Upstream up to 400°C (O₂ > 0%)
Downstream up to 900°C
- Combustion air: Up to 50°C, others on request
- Excess Air level: Minimum 20%

The information provided on this document is for information purposes only and does not constitute a legal obligation or a warranty, expressed or implied, of any kind.

CONTACT

itas.heatingsystems@fivesgroup.com
T +39 039 27331

Fives ITAS S.p.A.
Via Metauro, 5 – 20900 MONZA MB – Italy
www.fivesgroup.com

fives
Industry can do it