

## EcoFornax™ LEx North American 4215

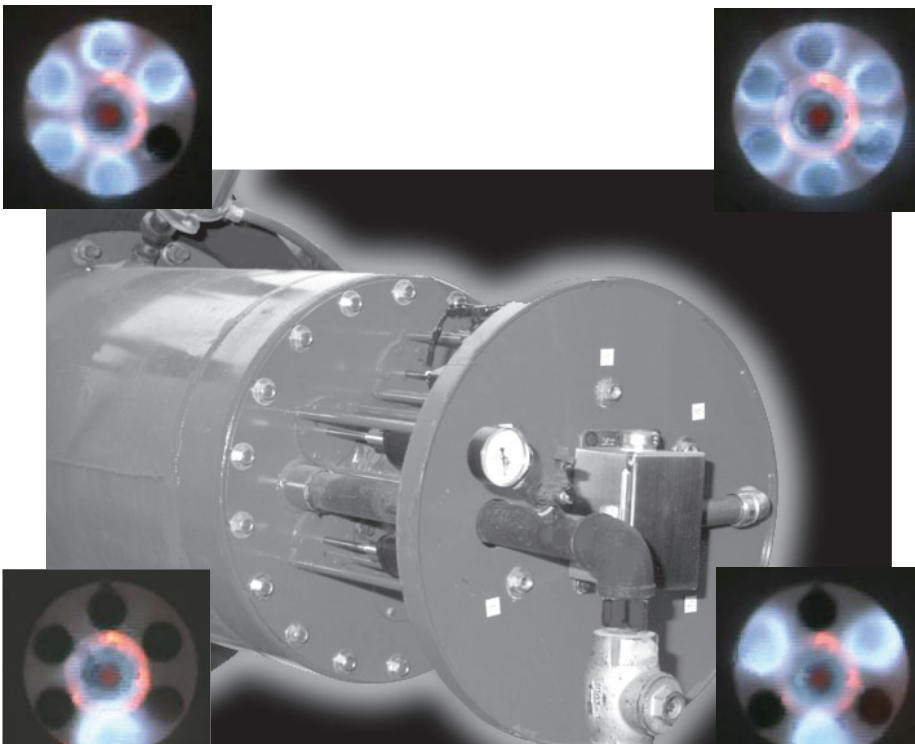

### Ultra-Low NOx LEx Rapid Response

- Ultra low NOx and CO without FGR
- Low to high fire in under 10 seconds
- Short, intense flame allows significant reductions in chamber size

# Product Overview | 4215 EcoFornax™ LEx

## APPLICATIONS:

- Through air dryers
- Aggregate dryers
- Yankee dryers
- Gypsum dryers
- Food ovens

The LEx Rapid Response system offers quick response to changes in process demands. An array of firing rates within the turndown range can be achieved in seconds by simple control of the burner-body-mounted staging system. Smooth, rapid transitions between operating points provide changes in heat input while maintaining continuous operation.

LEx systems greatly reduce the typical pollutants (NO<sub>x</sub> and CO) from natural gas combustion. Utilizing lean premix technology, the patented burner produces NO<sub>x</sub> emissions of less than 10 ppmv in many applications. CO emissions of less than 10 ppmv are achievable with the LEx burner reaction chamber installed with the burner. With over 80% of the combustion occurring in this specially designed reaction chamber, the compact flame geometry allows for a significant reduction in combustion chamber size and an overall lower installed cost.

## OPERATION

The burner incorporates patented internal mixing elements that pre-mix the fuel and air prior to combustion in the reaction zone. By completing a majority of the combustion in the burner reaction chamber, the low emissions of the burner are protected from process influences.

The burner is designed to operate at a nominal 10"wc main air pressure and 8 psig of gas pressure at high fire. Emissions performance is relatively insensitive to changes in firing rate. Overall thermal turndown of 15:1 is standard in most applications.

## CONTROL

The burner incorporates independently controlled linearly-actuated valves into the framework of the primary mixing elements. The valves provide rapid, smooth transition to distinct firing rates. A characterizable mass flow ratio control system is recommended for optimum emissions tuning and finer firing rate control.

## IGNITION AND FLAME SUPERVISION

A spark ignited, separately controlled radial flame burner serves as the pilot. This integral system operates during standard LEx operation and acts to anchor the main flame, providing stable combustion at all firing rates. A single UV scanner monitors both the main and radial flame.

## BURNER CONSTRUCTION

The burner is of robust construction suited for industrial applications. Separate bosses for the radial flame igniter and UV detector can be positioned in any of several locations.

The linearly-actuated mixer control valves are housed in a protective structure, and are easily removed for maintenance. The lifetime of the valve has been tested to 250,000 cycles.

## OTHER FUELS

The LEx burner can fire many gaseous fuels with similar low emission performance. The LEx burner with an appropriately designed reaction chamber makes it extremely effective for firing low Btu gases. Consult your Fives North American Combustion, Inc. Sales and Application Engineer for your specific needs.

## NO<sub>x</sub> and CO Emissions Comparison

process temperature at 1200°F

	Emissions at High Fire		Emissions at 5:1 Turndown	
	Typical cold air burner	LEx Rapid Response	Typical cold air burner	LEx Rapid Response
NO <sub>x</sub>	82	9	107	13
CO	20	5	200	5
Emissions ppmv, corrected to 3% O <sub>2</sub>				

## Flow Control Concept

**Figure 1. Typical Control Concept for Single Burner LEx Combustion System.**

A characterizable mass flow ratio control system is recommended for tailoring burner ratio through turndown.

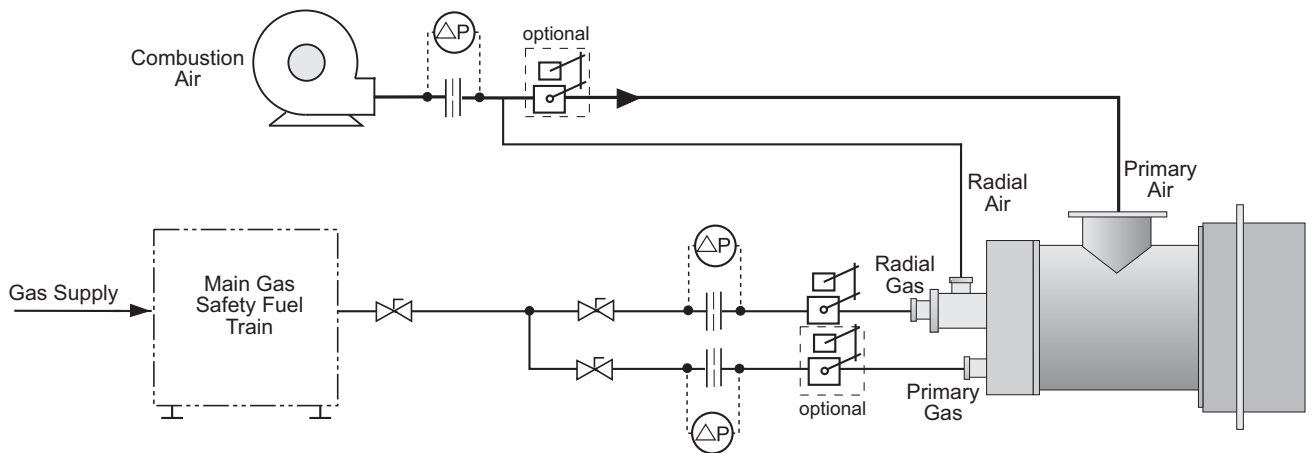

## Simplified Burner Design — No FGR

**Figure 2.** The LEx uses patented premix technology to establish a lean premix and then combusts the mixture in a controlled reaction zone without the use of FGR or complex staging devices. The fuel and air are introduced separately into the burner where they are intimately mixed within anti-flashback mixers. This mixture is then directed into the reaction region where lean combustion takes place.

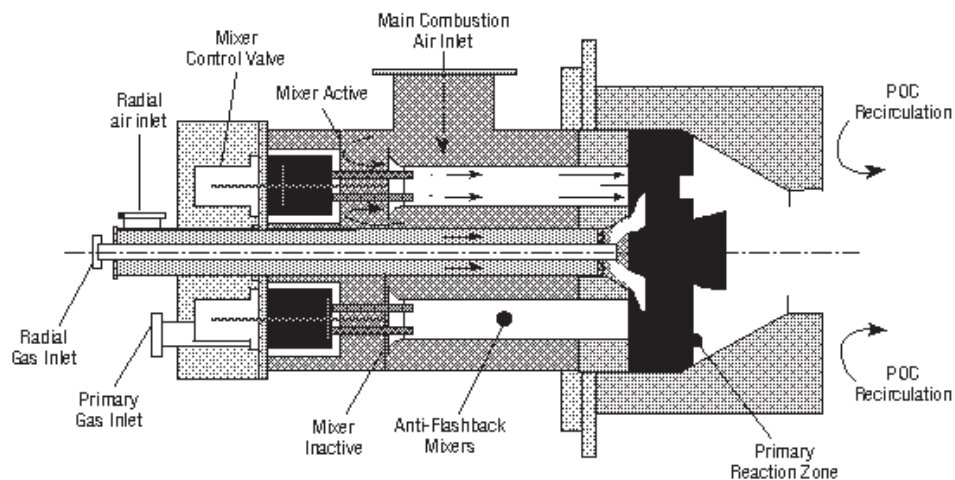

# Response Time | 4215 EcoFornax™ LEx

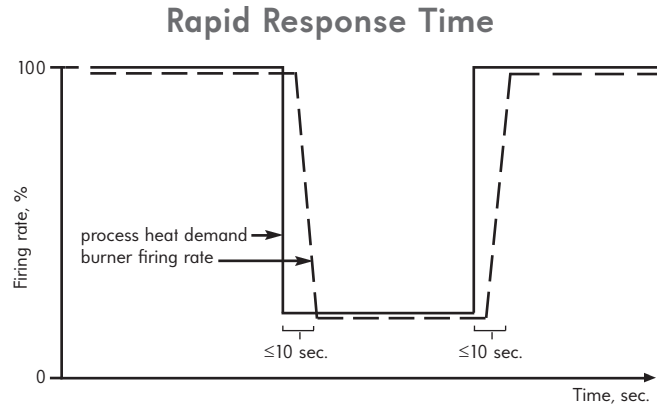

**WARNING:** Situations dangerous to personnel and property may exist with the operation and maintenance of any combustion equipment. The presence of fuels, oxidants, hot and cold combustion products, hot surfaces, electrical power in control and ignition circuits, etc., are inherent with any combustion application. Components in combustion systems may exceed 160°F (71°C) surface temperatures and present hot surface contact hazard. Fives North American Combustion, Inc. suggests the use of combustion systems that are in compliance with all Safety Codes, Standards, Regulations and Directives; and care in operation.

## CONTACT

fna.sales@fivesgroup.com

T +1 800 626 3477 - F +1 216 373 4237

**Fives North American Combustion, Inc.**  
4455 East 71st Street - Cleveland, OH 44105 - USA  
[www.fivesgroup.com](http://www.fivesgroup.com)



**fives**  
Industry can do it