



HIGH PRECISION
MACHINES

MATERIAL REMOVAL

Liné Machines RoboTDM

Robotic Solutions



Pioneer in material removal advanced manufacturing

Whether for aerospace, wind power generation, rail, or other industries, the Liné RoboTDM is a customized robotic solution that increases the overall efficiency of your trimming, drilling, and milling processes.

Thanks to our core competencies in milling machines, Fives offers advanced solutions for:

- **Trimming/contouring**
- **Milling (10 to 125 kW)**
 - Surfacing
 - Pocketing
- **Drilling**
 - Orbital and interpolate drilling
 - Countersinking/counterboring

Maximize your production resources

TRIMMING & MILLING

The Liné Machines RoboTDM can be equipped with versatile peripheral equipment and spindles for efficient machining for a wide range of hard and soft materials.

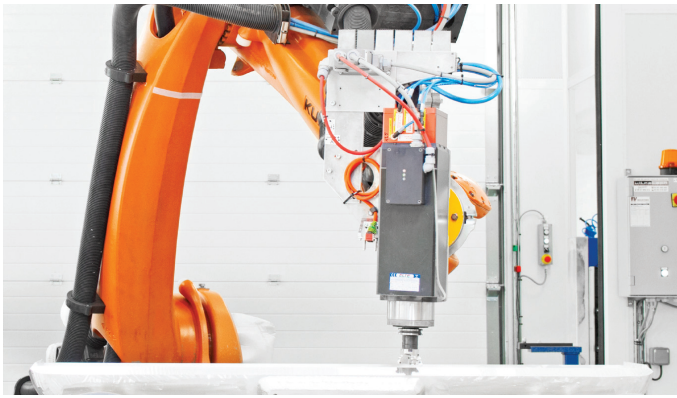

“Provides high material removal rates & outstanding performances.”

Spindle Specs Available

Power	Up to 125 kW
Torque	Up to 80 Nm
Speed	Up to 30,000 RPM
Taper	HSK A63, HSK F63, HSK A100
Spindle cooling	Grease or Air/Oil
Cooling media	Coolant or mist through spindle option

MAIN FEATURES

- Tool management
- Automatic tool changer
- Tool measurement system
- Tool breakage system
- Part probing system
- Multi workstations
- Robot protection shield

DRILLING

When used as a drilling machine, the Liné Machines RoboTDM is capable of drilling holes in either soft or hard materials. Many options are available considering the operations to be done.

- Orbital or interpolated drilling effector
- Countersinking / counterboring
- Vision system

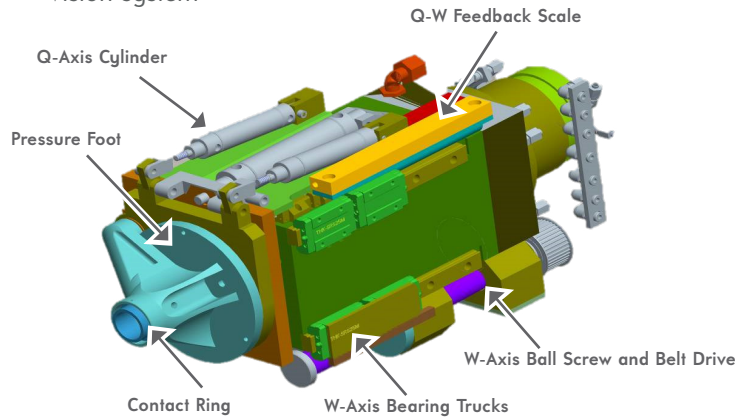

OTHER TECHNOLOGIES

Thanks to our recognized integration skills, we can propose various technologies to achieve the required parts, such as:

- Waterjet cutting
- Laser cutting
- Ultrasonic cutting



The information provided on this document is for information purposes only and does not constitute a legal obligation or a warranty, express or implied, of any kind.

CONTACT

Fives Liné Machines Inc.
flm.sales@fivesgroup.com
T +1 450 372-6480

Fives Liné Machines Inc.
1000, André-Liné Street, Granby, QC, J2J 1E2 — Canada
www.fivesgroup.com

